

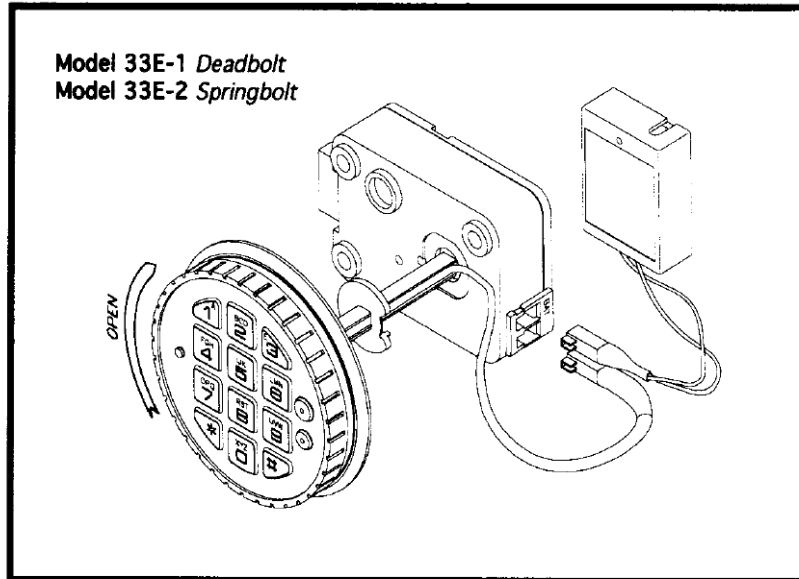

COMBOGARD

33E SERIES COMBINATION LOCK OPERATING INSTRUCTIONS



FEATURES

(May be activated at any time, by authorized service only.)

- **MANAGER MODE**
Add/Temporarily Disable/Remove second user.
- **TIME DELAY OVERRIDE**
Ability to add second combination to override Delay period.
- **DUAL COMBINATION**
Two combinations required to open.
- **SILENT SIGNAL ALARM** *(Optional Alarm Box Required)*
Duress Signal if last number of combination(s) entered one number higher or one number lower.
- **REMOTE OVERRIDE SIGNAL** *(Optional Alarm Box Required)*
Two combinations OR remote signal plus primary user combination required to open.
- **REMOTE DISABLE** *(Optional Alarm Box Required)*
- **TIME DELAY**
"Delay" period 1-99 minutes, "Open" period 1-19 minutes.

ACTIVE

CHANGING COMBINATIONS *(Lock signals twice after each valid entry.)*

- Enter six zeros.
- Enter old combination once.
- Enter new combination twice.
 - **Invalid Combination Entry** - Lock signals three times and old combination still valid.

ADD SECOND USER *(If manager, time delay override, remote override, or dual combination features activated.)*

- Enter primary user combination. HOLD DOWN LAST DIGIT OF COMBINATION until lock signals with **TWO** double beeps.
- **PRESS 1.** Lock signals twice.
- Enter second user combination twice. Lock signals twice after each valid entry.

DISABLE SECOND USER *(Manager feature only.)*

- Enter primary user combination. HOLD DOWN LAST DIGIT OF COMBINATION until lock signals with **TWO** double beeps.
- **PRESS 2.** Lock signals once.
- Second user is temporarily disabled.

REINSTATE DISABLED USER *(Manager feature only.)*

- Enter primary user combination. HOLD DOWN LAST DIGIT OF COMBINATION until lock signals with **TWO** double beeps.
- **PRESS 1.** Lock signals once.
- Second user is reinstated.

REMOVE SECOND USER *(Manager feature only.)*

- Enter primary user combination. HOLD DOWN LAST DIGIT OF COMBINATION until lock signals with **TWO** double beeps.
- **PRESS 3.** Lock signals once.
- Second user is permanently removed.

DUAL COMBINATION OPERATION *(If feature is active.)*

- Must add second user to open lock. (See ADD SECOND USER)
 - Second user can not be disabled or removed.
 - If Time Delay is active, one valid combination will start Delay period.
 - Both combinations required to open lock in Open period.
-

TIME DELAY *(If feature is active. Delay/Open times may be changed by authorized service only.)*

- Enter valid combination.
 - Delay period starts.
 - LED flashes red at one second intervals.
 - If valid combination entered during delay, Delay period restarts.
 - If invalid combination entered during delay, Delay period aborts.
- At end of delay period, Open period starts.
 - LED flashes red at 1/2 second intervals.
 - Lock beeps at 10 second intervals.
- During Open period, enter valid combination(s).
 - If invalid combination entered during open, Open Period continues.
 - If four consecutive invalid combinations entered Wrong Try Penalty starts.

TIME DELAY OVERRIDE *(If feature is active.)*

- Must add second combination. (See ADD SECOND USER)
 - Second combination can not be disabled/removed.
- Entry of override combination during Delay period will open the lock.

SILENT SIGNAL ALARM *(If feature is active AND optional Alarm Box connected.)*

- Enter last digit of combination(s) one number higher or one number lower.
Example:
- | | |
|-------------|----------------------------|
| Combination | 1-2-3-4-5-6 |
| Duress | 1-2-3-4-5-7 or 1-2-3-4-5-5 |

REMOTE OVERRIDE SIGNAL *(If feature is active AND optional Alarm Box connected.)*

- Remote signal plus primary user combination will open lock.
- If remote signal not active, needs a second user to open. (See ADD SECOND USER)
 - Second user can not be disabled/removed.

WRONG TRY PENALTY *(Standard feature.)*

- Entry of four consecutive invalid combinations initiates a 5-minute delay period. – LED flashes red at 10 second intervals.
 - At end of penalty period, two more consecutive invalid combinations will restart the 5-minute delay period.
-

CHANGING BATTERIES

- Repeated Beeping during an opening indicates that **battery is Low** and needs immediate replacement!
- Use one (1) 9-Volts Alkaline Battery or six (6) 1.5-Volts Alkaline Batteries Size C.

Model 2788 Battery Box (Standard)

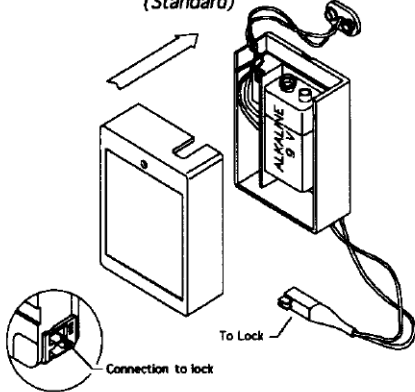

Model 4001 Large Battery Box (Optional)

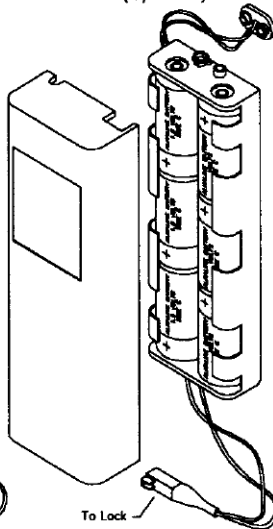

OPTIONS

Model 2789 Alarm/Battery Box (Optional)

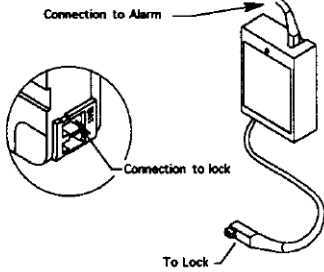

Model 4002 Large Alarm/Battery Box (Optional)

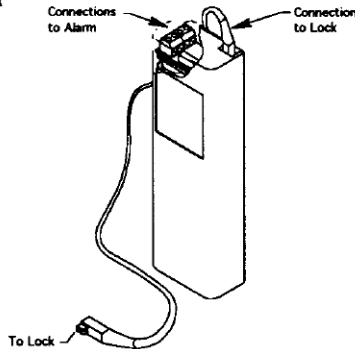

MODEL 2789 ALARM CONNECTIONS

4 wires 26 AWG.
Alarm Relay Connections:
 Red + Black =
 Normally Open (NO) or Normally Closed (NC)
 Relay contacts - Settable
 50 VDC @ 0.25 Amp Max load
Inputs Disable or Remote Override
 Yellow = Positive input
 Green = Negative input
 5-12 VDC @ 20 mA Max input

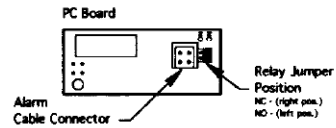

MODEL 4002 ALARM CONNECTIONS

Alarm Relay
 Out - 50 VDC @ 0.25 Amp Max
 Input - 5-12 VDC @ 20 mA Max

Inputs Disable or Remote Override

